



4
Years
Warranty

* on transmission units

fantiniworld.com



fantini

the best harvest since 1968

50

fantini
1968 | 2018
fantiniworld.com
made in italy



SUNFLOWER HEADERS

MADE IN ITALY



AL qualita

LAVERDA

fantini

the best harvest since 1968

THE COMPANY

FANTINI is a leading company in the production of corn and sunflower headers, products that can be applied to all kinds or models of combine. The company exponential development confirms the capability to satisfy a demanding clientele. Planning versatility is the preogative that differentiates FANTINI from combine harvester manufacturers that provide similar but standard products.

FANTINI was formed in 1968 and since the beginning has been based in Medole, in the province of Mantua (Northern Italy), just 120 km far from Milan. Its premises cover an area of 20.000 square metres, 9.000 of which are occupied by a modern plant fitted with high tech equipment and machinery.

FANTINI prerogative is high quality and robustness. Each component is checked before being placed on the assembly and varnishing line. Design and production engineers are part of the Research and Development department. They have matured a wide experience, that enables them to carry out any type of changes and prototypes to satisfy all customers' needs, in compliance with high quality, robustness and reliability standards.

Nowadays FANTINI export 97% of their products all over the world, with the contribution of a wide network of authorized dealers. FANTINI participates to the most important exhibitions all over the world.



fantiniworld.com

GO3



N°

different number of rows available on request

2 > 16
6 > 16



different row spacing available on request

cm 70-75-80
cm 45-50

GH3



N°

different number of rows available on request

6 > 12
6 > 16



different row spacing available on request

cm 70-75-80
cm 45-50

TECHNICAL DETAILS



Simple and sturdy construction

The simple and sturdy construction of Fantini's sunflower (and corn) headers guarantees a faultless performance over time.

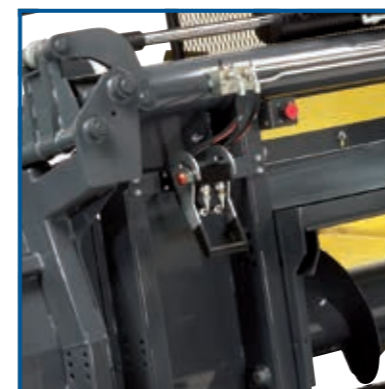
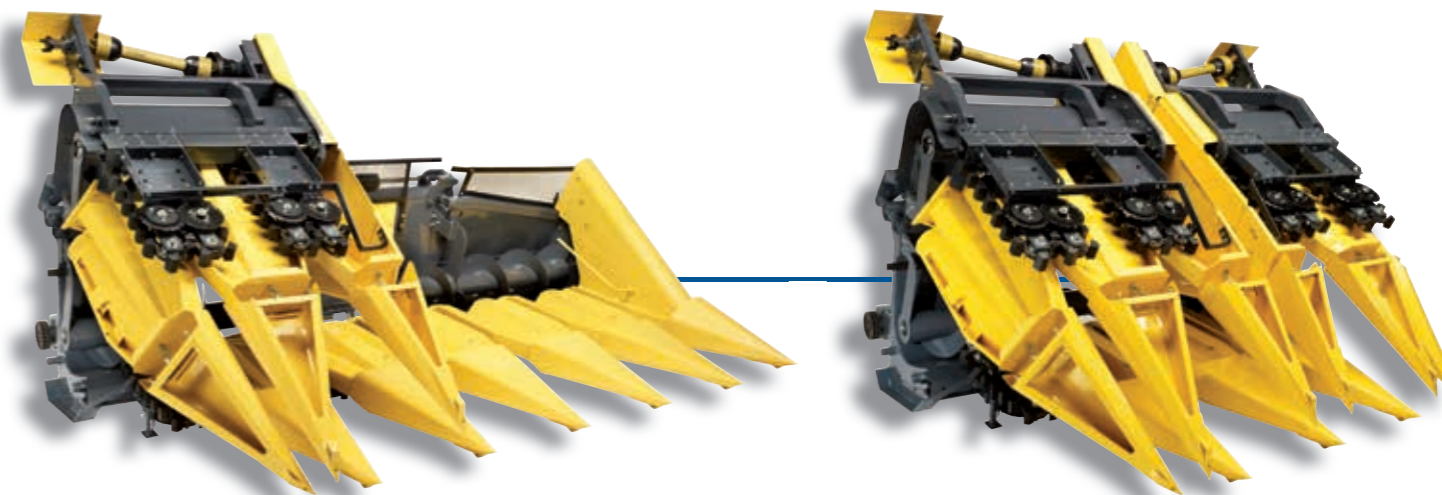

Attachment kit with adjustable inclination

Thanks to the use of interchangeable attachment kits, the sunflower headers can be easily connected to all types of combines.

A kit can be easily changed without specialized assistance.



Specially designed central bonnets

The basin shaped central bonnets, which are tilted backwards, gather the seeds which fall before reaching the conveying auger.



Divider tips

The long divider tips, which can be folded during transportation, make the harvest of fallen or flattened plants easier.



GATHERING ELEMENTS

The gathering elements are connected by chain joints which can be dismantled therefore reducing the maintenance needs of the header.

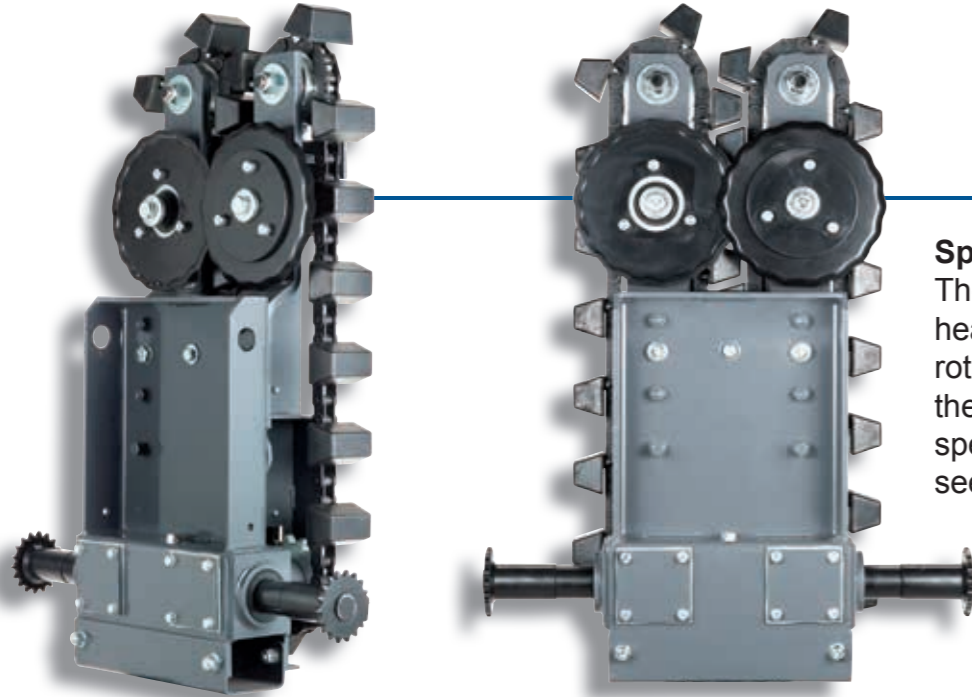

Special cutting system

The cutting system of the sunflower header is performed by two counter rotating disks which don't shake the plant and allow high harvesting speed without either vibrations or seed loss.

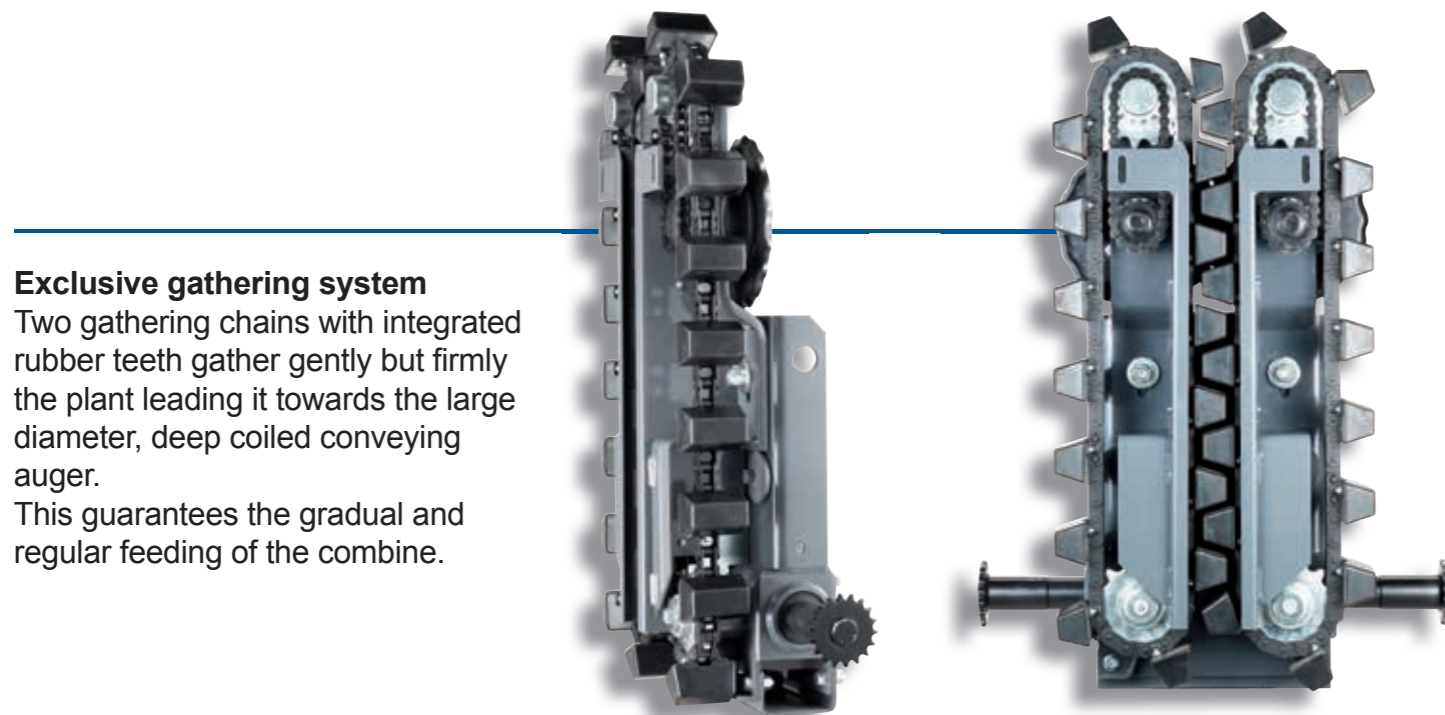

Exclusive gathering system

Two gathering chains with integrated rubber teeth gather gently but firmly the plant leading it towards the large diameter, deep coiled conveying auger.

This guarantees the gradual and regular feeding of the combine.

ASSISTANCE

Fast assistance service

- Testing and assistance performed by qualified technician
- Real-time assistance
- Assistance available 7 days a week
- Overhauls during winter season on request

SPARE PARTS

Spare parts service

- Spare parts warehouse constantly resupplied
- Authorized distributors

ACCESSORIES

Accessories on request:

- Light bar
- Double transmission
- Spare parts kit





CSQA
SISTEMA QUALITÀ CERTIFICATO
UNI EN ISO 9001 — CERT. n° 34146



Published by Fantini Srl. All rights reserved.

fantini
the best harvest since 1968

Via Brigoni 2/6, 46046 Medole (MN) Italy
Tel. +39 0376 868202 - Fax +39 0376 899004
sales@fantiniworld.com